

# SPECIFICATION

## SERVICE SADDLE DOUBLE BALE

### MODEL 313

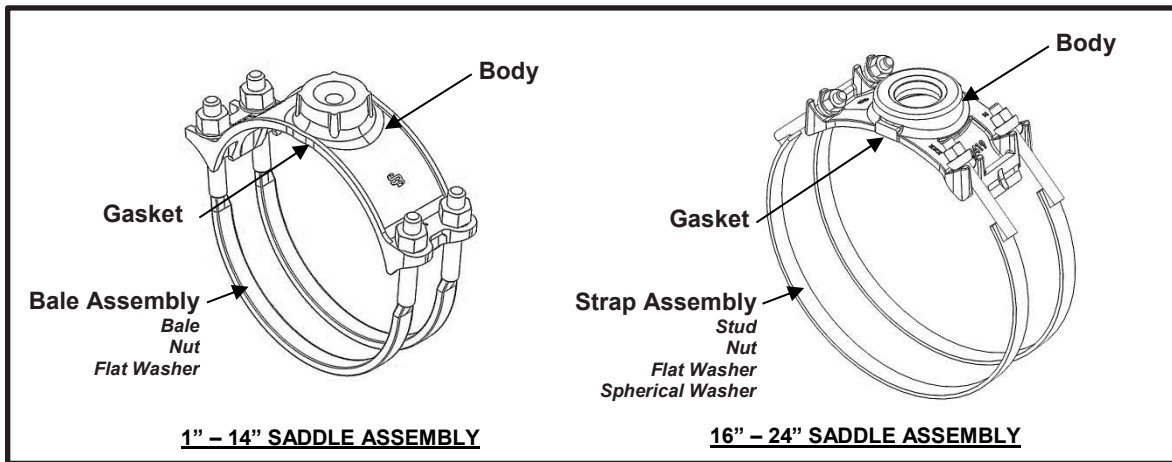

#### APPLICATIONS

- **Typical Uses**
  - Tapping branch connections on new or existing pipe
  - Installing air/vacuum valves, pitot tubes, drain valves, or other miscellaneous service equipment
  - Installing pipe supports, hangers, or sign mounting brackets
- **Standard Pipe Sizes**
  - 1.25" to 24" nominal
- **Standard Taps**
  - NPT: 1/2", 3/4", 1", 1-1/4", 1-1/2", 2", 3" and 4"
  - CC/AWWA: 1/2", 5/8", 3/4", 1", 1-1/4", 1-1/2" and 2"
  - BSP: 1/2", 3/4", 1", 1-1/4", 1-1/2", 2", and 3"

*See Smith-Blair catalog for available pipe diameter and tap size combinations as some combinations are not available*
- **Type of Pipe**
  - Carbon Steel, Stainless Steel, Ductile Iron, Asbestos Cement, Aluminum
- **Working Pressure**
  - Up to 300 psi depending on type of pipe, type of repair, pipe diameter, service conditions, and installation workmanship

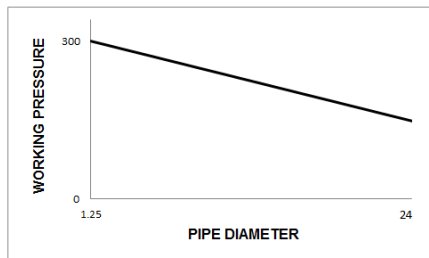



# SPECIFICATION

## SERVICE SADDLE DOUBLE BALE

### MODEL 313

---

#### MATERIALS

- **Body** (*Small (ST) and Large (LT) Tap sizes 1/2" – 2-1/2"*)
  - Cast using Ductile Iron 65-45-12 per ASTM A536
  - Flexi-Coat® fusion bonded epoxy finish which meets application methods AWWA C213
  - Closed ears holds nut and bale in place allowing the assembly to hinge for ease of installation around pipe
  - Open ears provide easy slip on installation and removal of nuts are not required preventing lost hardware
  - Canted ears for maximum tangential tightening of bale or strap
  - Wraparound design provides maximum pipe support, reinforcement, and sealing pressure
  - Wide skirt and heavy tapping boss provides excellent stability on the pipe
- **Body** (*Extra-Large (XLT) Tap sizes 3" and 4"*)
  - Cast using Ductile Iron 65-45-12 per ASTM A536
  - Flexi-Coat® fusion bonded epoxy finish which meets application methods AWWA C213
  - Open ears provide easy slip on installation and removal of nuts are not required preventing lost hardware
  - Canted ears for maximum tangential tightening of bale or strap
  - Wraparound design provides maximum pipe support, reinforcement, and sealing pressure
  - Wide skirt and heavy tapping boss provides excellent stability on the pipe
- **Gasket**
  - Nitrile (Buna-N) per ASTM D2000
  - Certified to NSF/ANSI 61-G& 372
  - Compounded to resist water, oil, natural gas, acids, alkalies, most (aliphatic) hydrocarbon fluids, and many other chemicals
  - Temperature range: -20°F to +180°F
  - TaperSeal™ hydro-mechanical lip enables the saddle to hold higher pressures with minimal nut torque
  - Gasket is fully cemented in a cavity to hold it in place
- **Bale Assembly** (*used only on 1.25" - ~14" nominal pipe size saddles with 1/2" thru 4" tap sizes*)
  - **Bale**
    - HSLA Carbon Steel per AWWA C111/A21.11
    - Fe/Zn Coated per ASTM F1941-10
    - Size: 1.25" – 3" nominal pipe size = 1/2"-13UNC  
4" – 14" nominal pipe size = 5/8"-11UNC  
Extra-Large (XLT) Taps < 14.73" O.D. = 5/8"-11UNC
    - Pipe contact surface flattened to provide a wider bearing surface against pipe
    - Rolled threads for improved physical characteristics, greater thread accuracy, and smooth surface finish
  - **Nut**
    - Carbon Steel per ASTM A307
    - Fe/Zn Coated per ASTM F1941-10
    - Size: 1.25" – 3" nominal pipe size = 1/2"-13UNC Heavy Hex Semi-Finished  
4" – 14" nominal pipe size = 5/8"-11UNC Heavy Hex Semi-Finished  
Extra-Large (XLT) Taps < 14.73" O.D. = 5/8"-11UNC Heavy Hex Semi-Finished
  - **Flat Washer**
    - Carbon Steel per ASTM F844
    - Fe/Zn Coated per ASTM F1941-10
    - Size: 1.25" – 3" nominal pipe size = 1/2" Type A Plain  
4" – 14" nominal pipe size = 5/8" Type A Plain  
Extra-Large (XLT) Taps < 14.73" O.D. = 5/8" Type A Plain
    - Fe/Zn Coated per ASTM F1941-10



# SPECIFICATION

## SERVICE SADDLE DOUBLE BALE

### MODEL 313

- 
- **Strap Assembly** *(used only on 16" - 24" nominal pipe size saddles with 1/2" thru 2-1/2" tap sizes)*
    - **Strap**
      - Carbon Steel per ASTM A36
      - Flexi-Coat<sup>®</sup> fusion bonded epoxy finish which meets application methods AWWA C213
      - Formed using 0.25" x 1.25" flat bar
      - Provides continuous circumferential support of the pipe for better performance in the tapped area (nearly 360°)
    - **Stud**
      - HSLA Carbon Steel per AWWA C111/A21.11
      - Flexi-Coat<sup>®</sup> fusion bonded epoxy finish which meets application methods AWWA C213 (threads free from epoxy coating)
      - 5/8"-11UNC, Stud welded to Strap
      - Rolled threads for improved physical characteristics, greater thread accuracy, and smooth surface finish
    - **Welding**
      - Welds accomplished using qualified welders
      - GMAW weld process utilized
    - **Nut**
      - Carbon Steel per ASTM A307
      - 5/8"-11UNC Heavy Hex Semi-Finished
      - Fe/Zn Coated per ASTM F1941-10
    - **Flat Washer**
      - Carbon Steel per ASTM F844
      - 5/8" Type A Plain
      - Fe/Zn Coated per ASTM F1941-10
    - **Spherical Washer** *(used only on 16" - 24" nominal pipe size saddles)*
      - Cast using Ductile Iron 65-45-12 per ASTM A536
      - Flexi-Coat<sup>®</sup> fusion bonded epoxy finish which meets application methods AWWA C213
      - Provide full bearing for the strap nuts and align the straps with the saddle body
      - Distributes load for better performance



# SPECIFICATION

## SERVICE SADDLE DOUBLE BALE

### MODEL 313

- **Strap Assembly** (*used only on 14" - 18" nominal pipe size saddles with 3" and 4" tap sizes*)
  - **Strap**
    - Carbon Steel per ASTM A36
    - Flexi-Coat® fusion bonded epoxy finish which meets application methods AWWA C213
    - Formed using 0.25" x 1.75" flat bar
    - Provides continuous circumferential support of the pipe for better performance in the tapped area (nearly 360°)
  - **Stud**
    - HSLA Carbon Steel per AWWA C111/A21.11
    - Flexi-Coat® fusion bonded epoxy finish which meets application methods AWWA C213 (threads free from epoxy coating)
    - 3/4"-10UNC, Stud welded to Strap
    - Rolled threads for improved physical characteristics, greater thread accuracy, and smooth surface finish
  - **Welding**
    - Welds accomplished using qualified welders
    - GMAW weld process utilized
  - **Nut**
    - Carbon Steel per ASTM A307
    - 3/4"-10UNC Heavy Hex Semi-Finished
    - Fe/Zn Coated per ASTM F1941-10
  - **Flat Washer**
    - Carbon Steel per ASTM F844
    - 3/4" Type A Plain
    - Fe/Zn Coated per ASTM F1941-10
  - **Spherical Washer**
    - Cast using Ductile Iron 65-45-12 per ASTM A536
    - Flexi-Coat® fusion bonded epoxy finish which meets application methods AWWA C213
    - Provide full bearing for the strap nuts and align the straps with the saddle body
    - Distributes load for better performance

#### LISTINGS

- Certified to NSF/ANSI 61-G & 372
- Meets applicable AWWA C800 standards

#### OPTIONS

- Type 304 Stainless Steel bale assembly with fluoropolymer coated nuts to prevent galling
- Type 316 Stainless Steel strap assembly with fluoropolymer coated nuts to prevent galling (*spherical washers remain D.I*)
- Electro-galvanized strap assembly
- Alternative gasket material (e.g. Viton, EPDM, etc.)
- Anode connector

#### NOTES

- These product specifications were correct at the time of publication and are subject to change without notice
- Flexi-Coat® is a registered trademark of Smith-Blair, Inc.
- Taperseal™ is a trademark of Smith-Blair, Inc.
- See the Smith-Blair® web site for part numbers and ordering information
- See the Smith-Blair® web site for warranty information
- See the Smith-Blair® web site for corrosion warnings

30 Globe Ave, Texarkana, AR 71854  
Ph: 870-773-5127 • Fax: 870-773-5212  
Toll-Free Numbers: Ph: 800-643-9705 • Fax: 800-648-6792

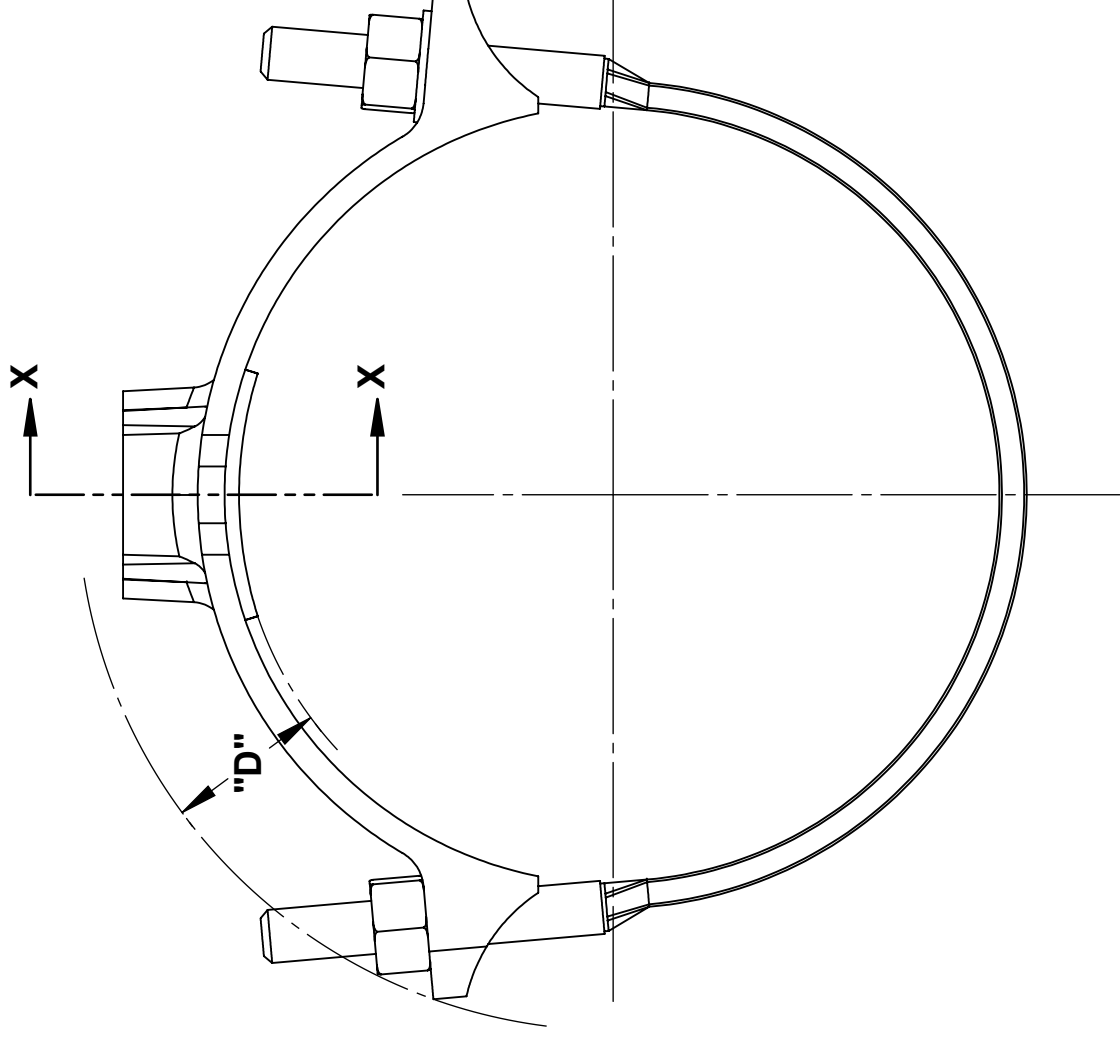
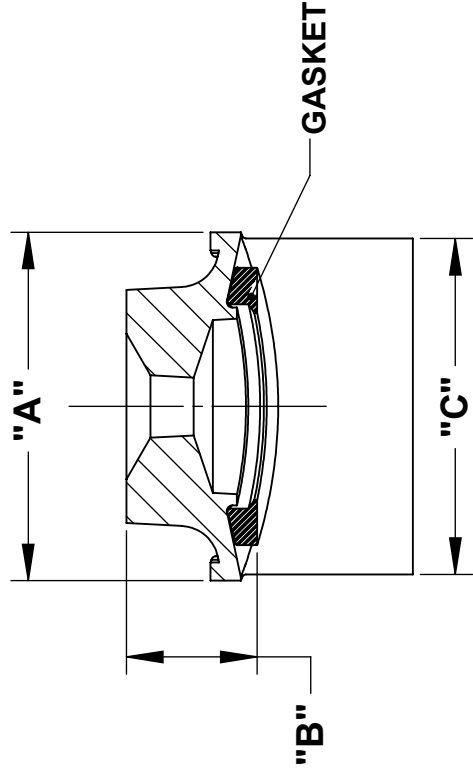

NOMINAL SIZE	APPROX. WT. (LB)	TAP CODE	A	B	C	D	SOCKET SIZE
1.25 - 2.50	3	ST	3.40	1.35	2.88	1.53	7/8"
	-	LT	-	-	-	-	
3	4	ST	3.40	1.40	3.00	1.70	7/8"
	5	LT	4.40	1.40	3.60	1.65	
4	6	ST	3.70	1.40	3.50	1.60	1-1/16"
	6	LT	5.50	1.75	3.65	1.75	
5	6	ST	3.70	1.40	3.60	1.75	1-1/16"
	9	LT	5.50	1.75	3.65	1.70	
6	7	ST	3.75	1.40	3.60	1.75	1-1/16"
	7	LT	5.50	1.75	3.65	1.78	
8	13	XLT	6.05	1.93	4.20	1.83	1-1/16"
	8	ST	3.75	1.40	3.60	1.87	
10	11	LT	5.50	1.75	3.65	1.90	1-1/16"
	15	XLT	6.05	1.85	4.10	1.90	
12	10	ST	3.75	1.40	3.60	1.90	1-1/16"
	11	LT	5.50	1.75	3.60	1.90	
14	14	XLT	7.20	2.00	4.20	1.85	1-1/4"
	14	ST	3.75	1.45	3.60	2.00	
15-16	15	LT	5.50	1.75	3.60	1.95	1-1/4"
	18	XLT	7.20	2.00	4.20	1.85	
14	18	ST	4.45	1.40	2.85	1.90	1-1/4"
	18	LT	4.45	1.40	3.60	1.90	
15-16	28	XLT	7.20	2.00	4.20	1.85	1-1/4"
	19	ST	4.45	1.80	5.00	2.15	
15-16	19	LT	4.45	1.80	5.00	2.15	1-1/4"
	29	XLT	6.90	1.95	7.35	2.30	

CERTIFIED TO NSF/ANSI 61-G & 372

TOLERANCES U.N.O. XX= ±.03 XXX= ±.015 FRACTIONS=1/16 ANGLES=1° MACH. FIN.	NOTES: REMOVE BURRS AND SHARP EDGES DO NOT SCALE DWG.	APP'D	DATE
SCALE: N/A		CK'D	DATE
ALL DIMENSIONS ARE IN INCHES.		DRN	DATE
		CHD	DATE

- NOTES:**
- SEE SMITH-BLAIR CATALOG FOR AVAILABLE PIPE DIAMETER AND TAP SIZE COMBINATIONS AS SOME COMBINATIONS ARE NOT AVAILABLE
  - 9.05" SADDLE SHOWN OTHER SIZES SIMILAR
  - ABBREVIATIONS:  
ST = SMALL TAP SIZES 1/2" THRU 1-1/2"  
LT = LARGE TAP SIZES 1-1/2" THRU 2-1/2"  
XLT = EXTRA-LARGE TAP SIZES 3" AND 4"

**TITLE**  
**SPECIFICATION**  
**SERVICE SADDLE DOUBLE BALE**  
**MODEL 313**

P/N N/A

**SMITH-BLAIR, Inc.**  
 TEXARKANA, ARKANSAS

REV. 3/8/16

1 OF 2 SHEET

SPEC\_313.DRW

DWG. NO.

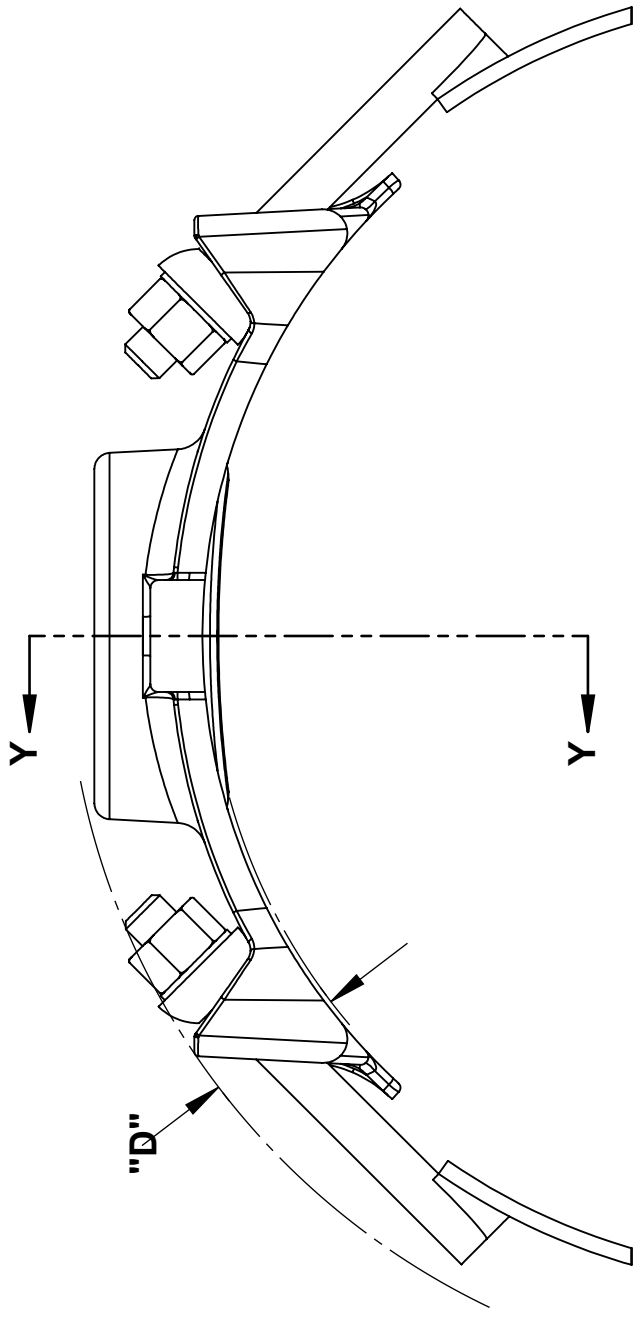
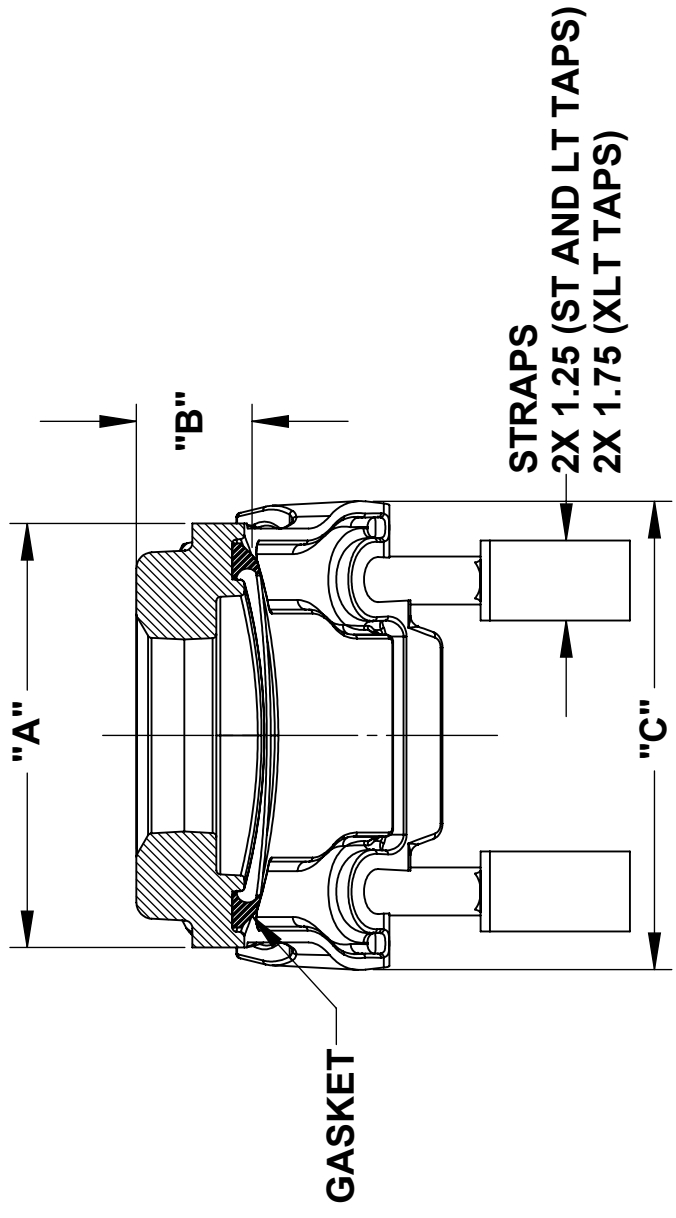

SECTION Y-Y

CERTIFIED TO NSF/ANSI 61-G & 372

NOMINAL SIZE	APPROX. WT. (LB)	TAP CODE	A	B	C	D	SOCKET SIZE
18	20	ST	4.45	1.85	4.95	2.15	1-1/16"
	20	LT	6.90	1.85	7.25	2.15	
	30	XLT	3.90	1.85	7.25	2.15	
20	20	ST	4.45	1.85	5.00	2.30	1-1/16"
	20	LT	4.46	1.90	5.00	2.10	
	-	XLT	-	-	-	-	
24	20	ST	4.45	1.85	5.00	2.30	1-1/16"
	20	LT	4.45	1.85	5.00	2.30	
	-	XLT	-	-	-	-	

- NOTES:**
- SEE SMITH-BLAIR CATALOG FOR AVAILABLE PIPE DIAMETER AND TAP SIZE COMBINATIONS AS SOME COMBINATIONS ARE NOT AVAILABLE
  - 19.50" XLT SADDLE SHOWN OTHER SIZES SIMILAR
  - ABREVIATIONS:  
 ST = SMALL TAP SIZES 1/2" THRU 1-1/2"  
 LT = LARGE TAP SIZES 1-1/2" THRU 2-1/2"  
 XLT = EXTRA-LARGE TAP SIZES 3" AND 4"

TOLERANCES U.N.O. XX= ±.03 XXX= ±.015 FRACTIONS= 1/16 ANGLES= ±1° MACH. FIN.	APP'D	DATE
	CK'D	DATE
	DRN	CHD
NOTES: REMOVE BURRS AND SHARP EDGES DO NOT SCALE DWG. SCALE: N/A		6/15/15
<b>TITLE</b> <b>SPECIFICATION</b> <b>SERVICE SADDLE DOUBLE BALE</b> <b>MODEL 313</b>		
<b>SMITH-BLAIR, Inc.</b> P/N N/A TEXARKANA, ARKANSAS		DWG. NO. <b>SPEC_313.DRW</b> 2 OF 2 SHEET REV. 3/8/16